

## MARTENSITIC TRANSFORMATION: AN APPROACH TO SIMULTANEOUS STUDY BY MICROSCOPY, CALORIMETRY AND ACOUSTIC EMISSION

V. TORRA

*Departament de Física, Facultat de Ciències, Universitat Illes Balears, Crtra. de Valldemossa km 7.5, 07071 Palma de Mallorca (Spain)*

J.M. GUILMANY

*Departament de Metal·lúrgia, Facultat de Química, Universitat de Barcelona, Av. Diagonal 645, 08028 Barcelona (Spain)*

E. CESARI

*Departament de Termologia, Facultat de Física, Universitat de Barcelona, Av. Diagonal 645, 08028 Barcelona (Spain)*

(Received 20 August 1985)

### ABSTRACT

This paper describes a preliminary device designed for observation through optical microscopy and simultaneous measurement of the acoustic emission (AE) and calorimetric signal.

### INTRODUCTION

Investigations on the  $\beta \rightleftharpoons$  martensite (m) transformations of copper alloys displaying a shape-memory effect show an important dependence on the thermomechanical history of the material. Observation of the evolution of different parameters with temperature (calorimetric signal, acoustic emission, resistivity variation) by different techniques has shown discrepancies among the different characteristics observed during transformation [1,2]. This fact has provoked great interest in the possibility of simultaneously observing the transformation and changes in the parameters.

### EXPERIMENTAL SET-UP

A block diagram of the experimental system is shown in Fig. 1. The calorimetric signal, by means of a variable offset (1-mV steps), makes it

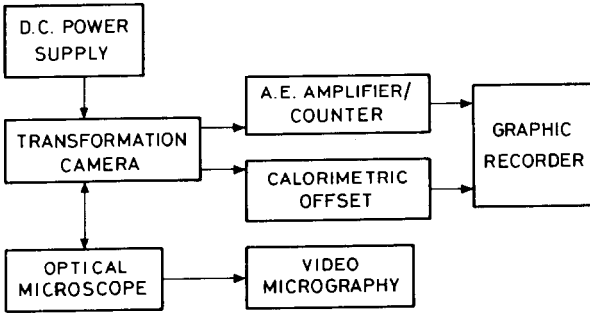

Fig. 1. Block diagram of the experimental device.

possible to work in a channel of the graphic recorder (Houston OmniScribe RT) at a scale of 1 mV. The acoustic signal coming from the piezoelectric captor is amplified (Bruel and Kjaer Preamplifier 2637, Amplifier 2638) and, via a counter-accumulator (construction GEMP-PM, INSA-Lyon), it activates the other channel of the recorder. Microscopic observation is carried out with an optical metallographic microscope (Leitz-Wetzlar) with a

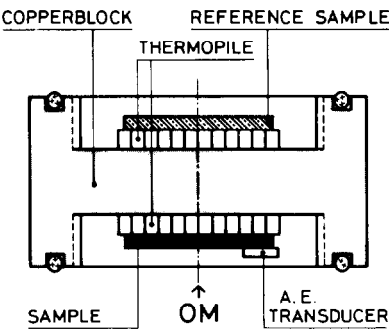
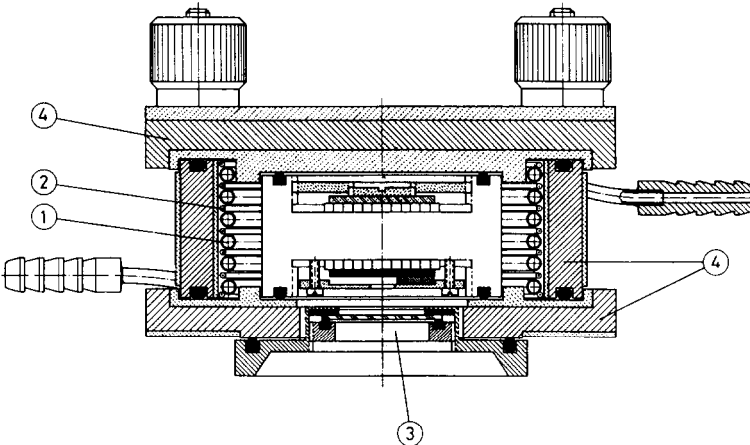

Fig. 2. (A) Experimental device; (1) cooling coil; (2) heating resistance; (3) observation window; (4) brass box. (B) Detail of calorimetric device.

Zeiss lens of long focal distance which allows direct observation of the surface of the material on a screen with the possibility of taking micrographic plates (video recordings, which can be useful for more accurate investigations, are beyond the aims of this paper).

The observation device is shown in Fig. 2. It has a conventional calorimetric device (sensibility  $\approx 350 \text{ mV W}^{-1}$  at room temperature) with the

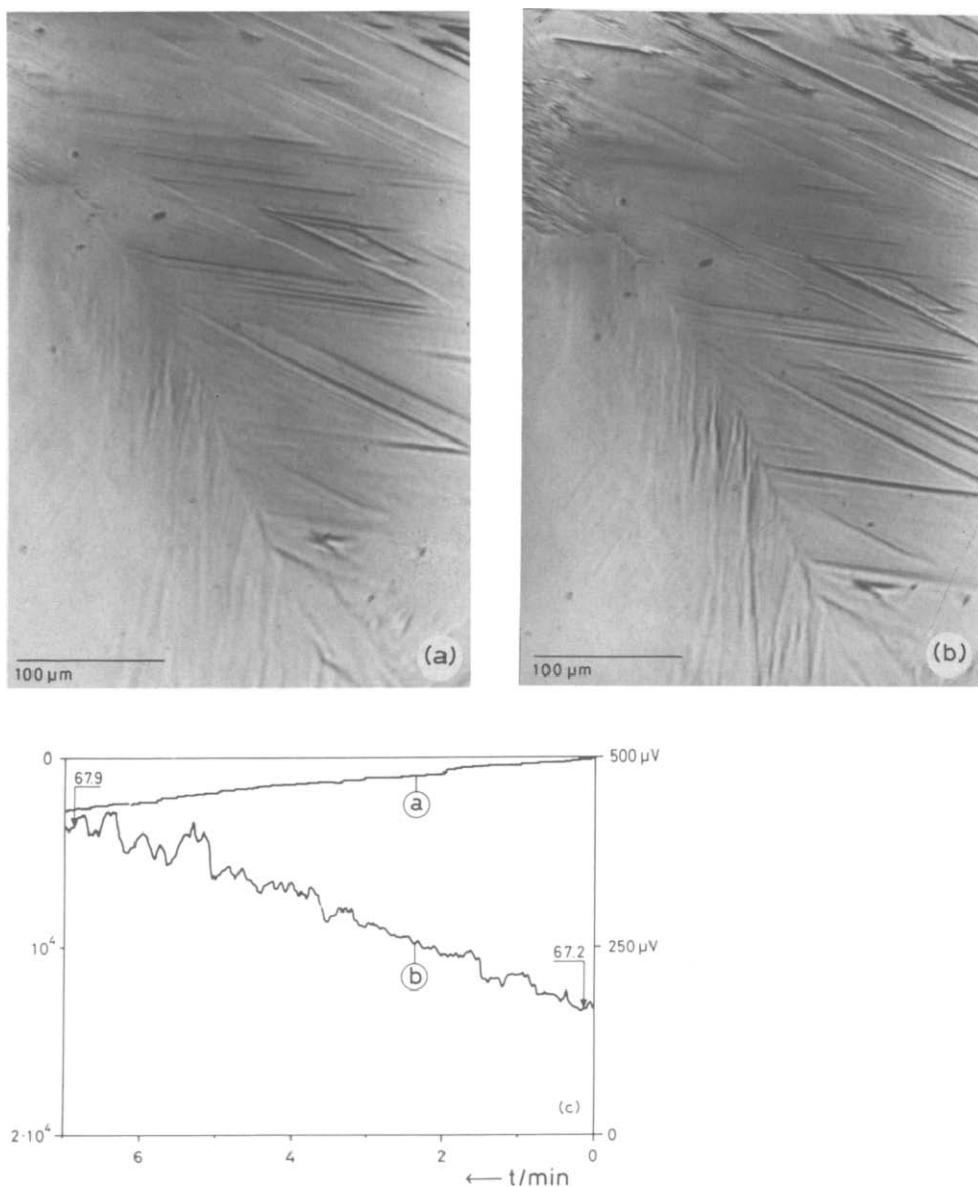

Fig. 3. Initial part transformation: (A) optical micrography ( $\times 260$ ),  $T = 67.2^\circ\text{C}$ ; (B) optical micrography ( $\times 260$ ),  $T = 67.9^\circ\text{C}$ ; (C) corresponding AE activity (cumulative number of counts) (a) and thermogram (b).

appropriate dynamic characteristics (first time constant  $\sim 10$  s) needed for observation of the transformation [1–3], with a semiconductor detector (MELCOR) and a piezoelectric capsule (Philips). The device is thermally protected by means of a nylon sheet and is placed inside a brass camera for easy manipulation.

In order to create a small temperature rise ( $\sim 0.1$  K  $\text{min}^{-1}$ ) a heating resistance (Thermocoax) fed by a standard DC power supply (Promax) is used. At this preliminary stage, the monitor is hand made.

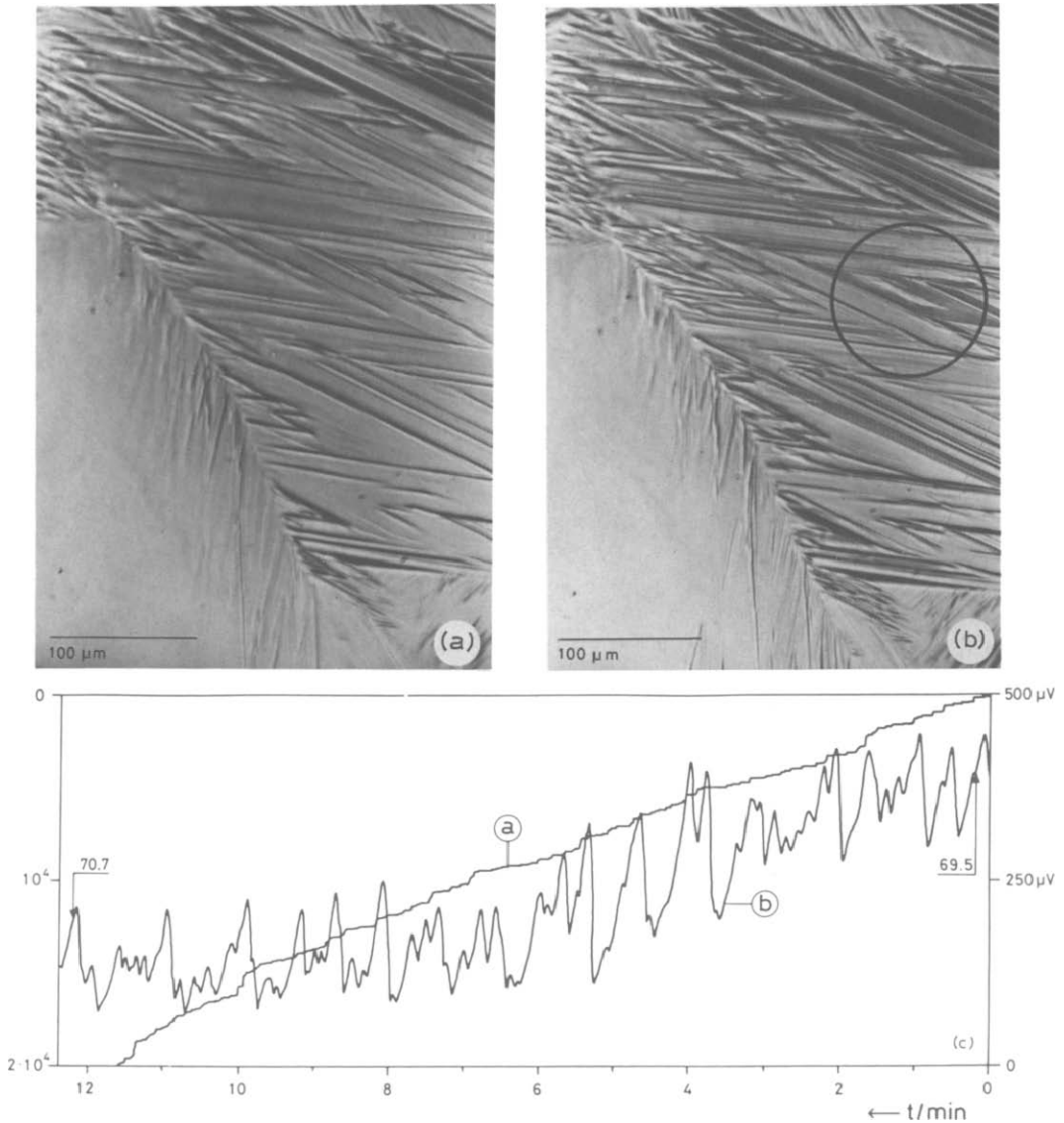

Fig. 4. Same zone of Fig. 3 with more advanced transformation: (A) optical micrography ( $\times 260$ ),  $T = 69.5^\circ\text{C}$ ; (B) optical micrography ( $\times 260$ ),  $T = 70.7^\circ\text{C}$ ; (C) corresponding AE activity (a) and thermogram (b).

## PRELIMINARY RESULTS

In order to analyse and control the possibilities of the system, we have used 1168 alloy (Cu/Al/Zn, 75.75 : 6.93 : 16.75, w/w/w). The same sort of alloy, provided by Dept. Metaalkunde, K.U. Leuven, has been used in developing assays for the simultaneous EA research and its observation by

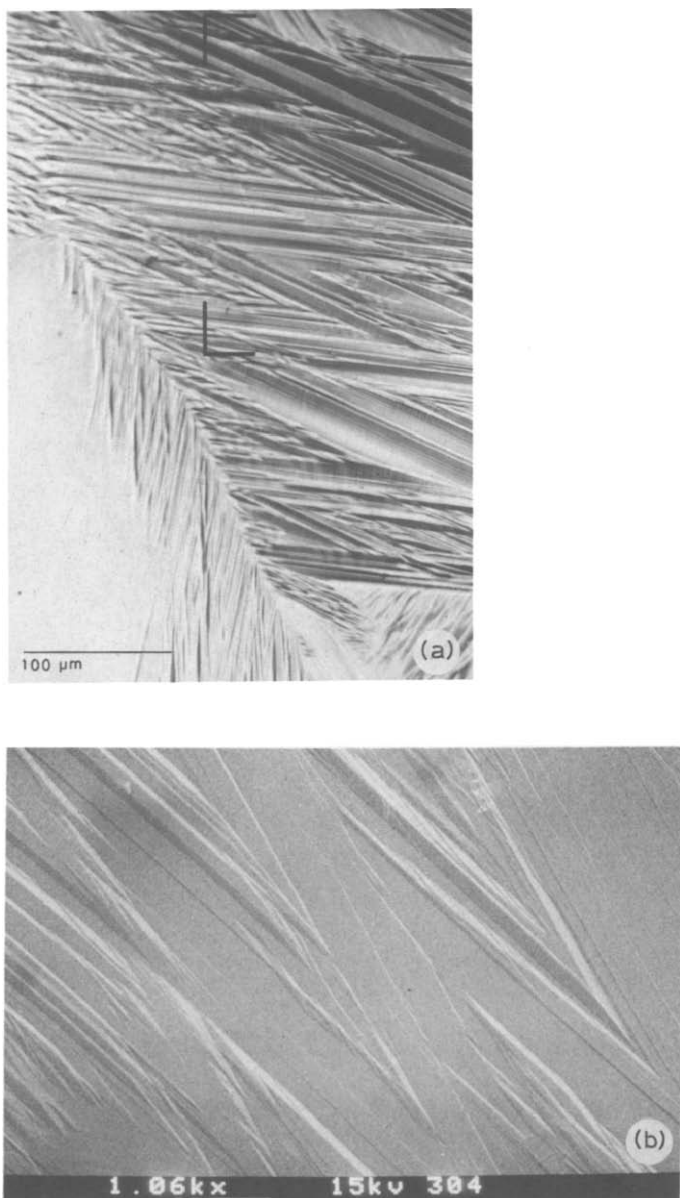

Fig. 5. (A) Optical micrography ( $\times 260$ ) of final structure,  $T = 82.7^\circ\text{C}$ . (B) SEM micrography ( $\times 1060$ ),  $T = 21.7^\circ\text{C}$ .

Scanning electron microscopy (SEM) [4].

Previous analyses were carried out in order to determine temperatures associated with the  $m \rightarrow \beta$  transformation, to suit the heat treatment described below, obtaining  $A_s \approx 50^\circ\text{C}$  and  $A_f \approx 75^\circ\text{C}$  [5]. The material was treated at  $750^\circ\text{C}$  for 15 min ( $\beta$ -phase), then quenched at  $0^\circ\text{C}$ , and finally tempered at  $80^\circ\text{C}$  for 1 h and air cooled ( $m$  phase). In order to guarantee good optical observation it is necessary to use a surface polished in the martensite phase, prepared by conventional manual techniques of grinding (up to 600 grain size) and polishing (up to  $1/4\text{-}\mu\text{m}$  diamond and colloidal silica). The experimental measurements began 48 h after heat treatment.

Figure 3 displays the initial part of the transformation; Figs. 3A and B correspond to surface evolution at temperatures of  $67.2$  and  $67.9^\circ\text{C}$ , respectively. The thermogram and the plot of acoustic emission appear in Fig. 3C. They show a change in surface structure.

Figure 4 corresponds to the same zone, when the transformation is more advanced. Figures 4A and B correspond to the temperatures  $69.5$  and  $70.7^\circ\text{C}$ , respectively. Figure 4C shows the thermogram and the plot of acoustic emission. Here there are not only superficial changes but also corrugated zones perpendicular to the preceding ones (see circled zone in Fig. 4B).

Figure 5A shows the final structure at  $82.7^\circ\text{C}$  ( $\beta$ -phase) by optical microscopy and Fig. 5B is an SEM micrograph at  $21.7^\circ\text{C}$  of a piece of the same zone (see zone marked in Fig. 5A) where the existence of an important residual relief can be observed.

## CONCLUSIONS

The experimental system developed allows the observation of superficial evolution due to martensitic transformation and associates it with the calorimetric signal and acoustic emission. The device allows observation of the  $20\text{--}110^\circ\text{C}$  zone in its present condition, which is basically the extent of the  $m \rightarrow \beta$  transition.

## ACKNOWLEDGEMENTS

This research has been carried out with the cooperation of the Universities of Barcelona (Dept. of Metallurgy and Dept. of Thermodynamics, Research Aid 1984) and Palma de Mallorca (Dept. of Physics, CAICYT project No. 3562-83). It is included in an international group which cooperates in the field of thermoelastic transformations (Dept. Metaalkunde, Katholieke Universiteit Leuven; GEMP-PM, INSA Lyon and Divisi3n de Metales, Centro At3mico de Bariloche, Argentina).

## REFERENCES

- 1 A. Planes and J.L. Macqueron, *An. Fis., Ser. B*, 78 (1982) 39.
- 2 R. Rapacioli, G. Guénin and J.L. Macqueron, *Proc. Jornades de Transformacions Termoe-lastiques*, Col. Conf. Commun., No. 1, Univ. Palma de Mallorca, 1984.
- 3 C. Picornell, C. Seguí, J. Hernáez and C. López del Castillo, *Thermochim. Acta*, 91 (1985) 311.
- 4 J. Ortín and D. Van Hulle, *Tech. Rep.*, Dept. Metaalkunde, Katholieke Universiteit Leuven, 1984, *Servei de Publicacions*, Universitat de Palma de Mallorca.
- 5 Ll. Mañosa, unpublished results.